



# CE100 & WTE100 Vandal & Weather Resistant Instrument Enclosures

## FEATURES and BENEFITS

### CE100 Enclosure

- Highly durable urethane construction
- Low and expanded profiles
- High integrity wall mounting
- Spring-loaded enclosure door with locking mechanical latch
- Threaded conduit entries
- Faceplate mounting flange and blind mounting holes
- Internal equipment mounting surfaces
- Optional colors

### WTE100 Enclosure

- Lightweight yet highly durable fire rated UV resistant PC/Siloxane material
- The lid is reinforced with ribs for additional strength
- Unique vise action latch ensures a consistent seal when closed
- Closed cell neoprene gasket provides a water tight seal
- High integrity wall mounting
- Spring-loaded enclosure door with non-locking mechanical latch
- Internal equipment mounting surfaces
- Optional key lockable latch
- Optional flat label area or custom embossed logo
- Stock or custom internal mounting plates and back pans are available

## APPLICATIONS (Instrument Enclosure)

- Onboard Ships
- Shipyards
- Off-Shore Platforms
- Dockside Warehousing
- Refineries
- Pulp and Paper Mills
- Chemical Plants
- Hydroelectric Facilities
- Oil & Gas Refineries
- Construction Sites
- Green Houses
- Roadside Call Boxes
- Tunnels
- Drilling Rigs
- Mines
- Recreation Facilities
- Ammonia Storage Area
- Fertilizer Plants
- and more ...

Guardian's CE100 & WTE-100 Vandal & Weather Resistant Instrument Enclosures are designed to withstand extreme environmental conditions. They are excellent enclosures for a wide variety of electronic instruments. Durable materials resist corrosive salt, spray, chemicals, desert dust and tropical humidity.

## INSTALLATION and CONNECTABILITY

### CE100 Enclosure

Mounts easily from the front of the unit to any vertical surface using 1/4" (6.35mm) fasteners and the powder coated steel mounting plate. Can be mounted from the back for added security. The housing is provided with 1/2" NPT threaded conduit entries.

### WTE100 Enclosure

Mounts easily from the front of the unit. Integral mounting feet eliminate the need for additional mounting plates. There are locator holes pre-dimpled for up to three 1" (25.4mm) nominal cable glands providing easy alignment and drilling.

**Guardian**  
Telecom Inc.

ISO 9001 Today's Quality Creates Our Future

OVERALL DIMENSIONS & ENGINEERING SPECIFICATIONS CE100 Vandal & Weather Resistant Instrument Enclosure

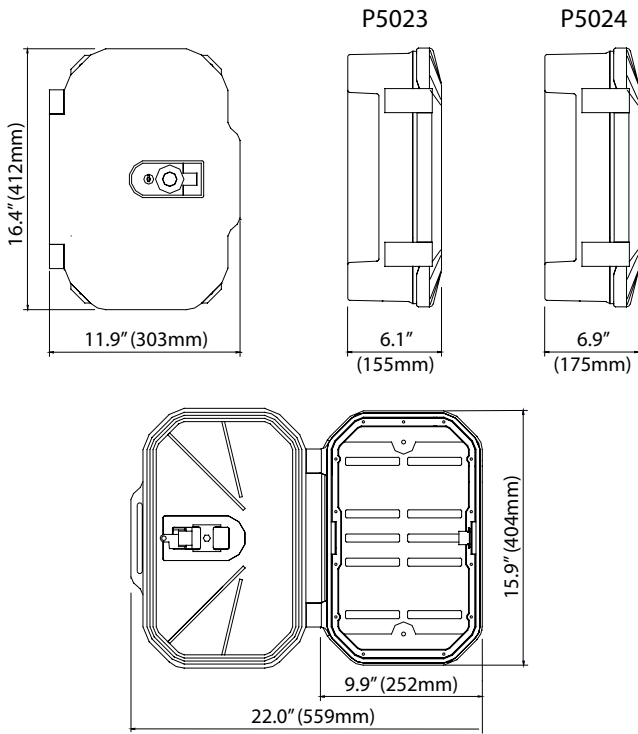

**MECHANICAL SPECIFICATIONS**

Body Construction Uniroyal LS750D Urethane  
 Mounting Vertical Wall  
 Hardware Material Stainless Steel  
 Faceplate Mounting Upper Plate Holes for #8 Self Tapping Screws  
 Lower Plate Not Supported

**CE100 Low Profile**

Dimensions (H x W x D) 16.2 x 11.9 x 6.1" (412 x 303 x 155 mm)  
 Interior Volume (H x W x D) 13.9 x 7.8 x 4.3" (353 x 198 x 109 mm)  
 Net Weight 11 lbs (5.25 kg)

**CE100 Expanded Profile**

Dimensions (H x W x D) 16.2 x 11.9 x 6.9" (412 x 303 x 175 mm)  
 Interior Volume (H x W x D) 13.9 x 7.8 x 5.1" (353 x 198 x 128 mm)  
 Net Weight 12 lbs (5.3 kg)

**ENVIRONMENTAL**

Waterproof Enclosure Regulatory CSA Type 4X  
 Class II, Groups E, F, G  
 Class III

**COMPLIANCE**

Fire Rating Equivalent UL94-V0

**ORDERING INFORMATION**

Warranty: One year parts and labor

Order Number	Description
P5023	CE100 Low Profile Urethane Enclosure with Locking Mechanical Latch
P5024	CE100 Expanded Profile Urethane Enclosure with Locking Mechanical Latch

**Options**

Color – The CE100 can be ordered in a variety of colors.\*  
 Handset Symbol – Graphic symbol printed on the enclosure cover.\*

\*Minimum quantities or premiums may apply. For details on custom options, contact a Guardian Telecom sales representative.

OVERALL DIMENSIONS & ENGINEERING SPECIFICATIONS WTE100 Vandal & Weather Resistant Instrument Enclosure

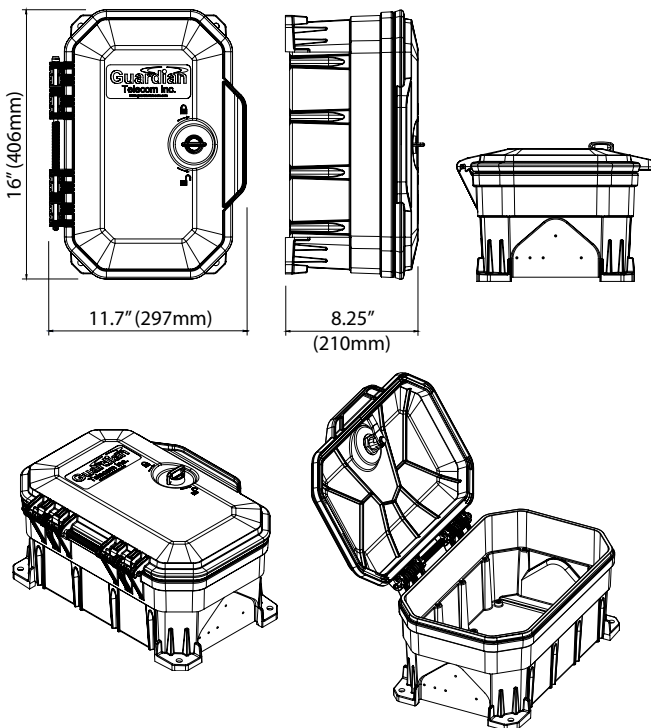

**MECHANICAL SPECIFICATIONS**

Body Construction Lexan® EXL9330  
 Mounting Vertical Wall  
 Hardware Material Stainless Steel  
 Faceplate Mounting Upper & Lower Plates #8-32 Threaded Inserts  
 Body Dimensions (H x W x D) 16 x 11.67 x 8.25" (406 x 297 x 210 mm)  
 Interior Volume (H x W x D) 14 x 8.5 x 7" (356 x 216 x 178 mm)  
 Net Weight 6.6 lbs (3 kg)

**ENVIRONMENTAL**

Waterproof Enclosure Regulatory (Pending) CSA Type 4X / IP66  
 Class II, Groups E, F, G  
 Class III  
 Temperature -31° to +176° F (-35° to +80° C)

**COMPLIANCE**

Fire Rating Equivalent UL94-V0  
 ROHS (Restriction of Hazardous Substances)

**ORDERING INFORMATION**

Warranty: One year parts and labor

Order Number	Description
P5025	WTE100 Lexan® EXL9330 Enclosure with Non-locking Latch

**Options**

Lock Key Lockable Latch

**Custom Orders**

Logo – Standard WTE-100 enclosures come with an embossed Guardian Telecom Logo on the cover. Customers can order enclosures with their Logos custom embossed on the cover or without embossing, suitable for customer applied graphics.\*

Colors – Custom enclosure colors are available.\*

Equipment Mounting – Stock or custom internal mounting plates and back pans are available\*

\*Minimum quantities or premiums may apply. For details on custom options, contact a Guardian Telecom sales representative.

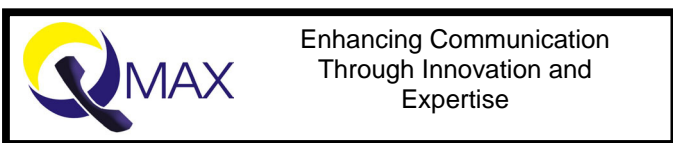

Guardian pursues a policy of continuous improvement, therefore specifications are subject to change without notice.

Qmax Group Pty Ltd.  
 Canning Vale, Western Australia  
 Ph (08) 9455-4671 Fax (08) 6210-1749  
 Email : info@qmax.net.au Internet : www.qmax.net.au