



SCR-11-A

SCR-41-A

SCR-11/41-A

Steel Compact Ringdown Telephones

Australian Version



FEATURES

- Encapsulated circuit boards impervious to water condensation and dust
- 16 gauge corrosion protected steel enclosure with powder coat finish
- Rust and corrosion resistant stainless steel hardware
- Electret noise reducing microphone
- Magnetic reed hook-switch reduces moving parts subject to wear
- Service temperature range from -40° to +60°C (-40° to +140°F)
- Heavy duty industrial handset
- SCR-11-A: Curly Cord
- SCR-41-A: Armored Cord

APPLICATIONS

- Refineries
- Power Generation Facilities
- Pulp and Paper Mills
- Food Processing Plants
- Chemical Plants
- Construction Sites
- Cement Plants
- Sewage Plants
- Drilling Rigs
- Hydroelectric Facilities
- Warehouses
- Mines
- Greenhouses
- and more ...

INSTALLATION and CONNECTABILITY

To provide flexibility and the potential for growth, Guardian's SCR Ringdown telephones can be easily and economically connected to any telephone network through standard wiring and parts. Voice quality is unaffected when phones are connected within ~ 4,600 meters (15,000 ft.) of a main telephone switch supporting single line telephones. Meeting safety standards may require special wiring conduits or other considerations. Order the SCR Ringdown separately or as part of an integrated system.

ACCESSORIES and OPTIONS

- 6 meter (20') Handset Curly Cord on SCR-11-A only

Guardian's SCR-11-A / 41-A Ringdown telephones are designed for harsh environments requiring special communication needs, ensuring high quality communications under extreme working conditions. As soon as the receiver is lifted the SCR-11-A / 41-A automatically connects the caller to an assigned PBX location.

Guardian
Telecom Inc.

ISO 9001 Today's Quality Creates Our Future

OVERALL DIMENSIONS

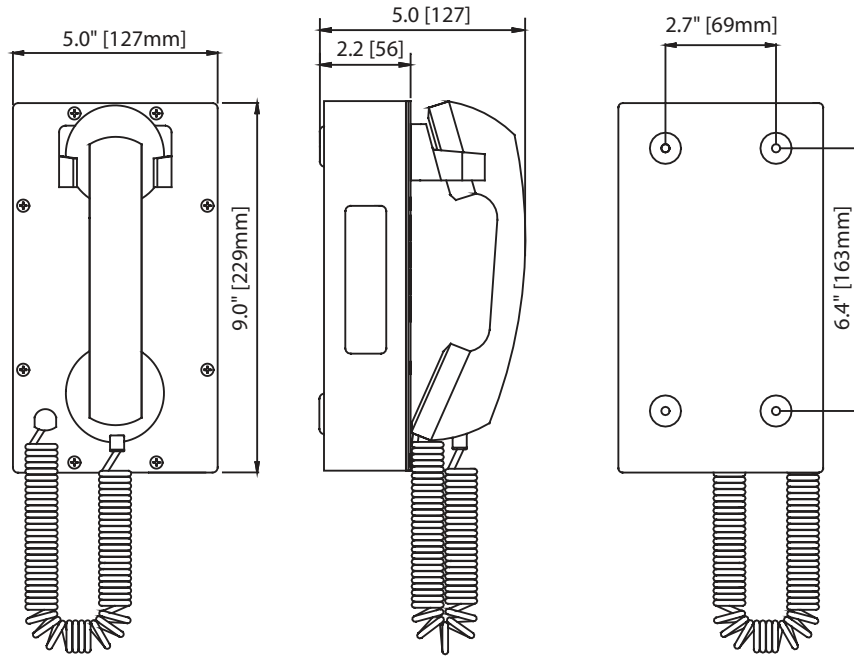

SCR-11/41-A Steel Compact Ringdown Telephones

ENGINEERING SPECIFICATIONS

ELECTRICAL PERFORMANCE

Audio Range Frequency Response	300 - 3400 Hz
Connection Method	Hotline Operation
Send Loudness Rating (SLR)	Short 8 dB +/-4 dB
Receiver Loudness Rating (RLR)	Short -4 dB +/-4 dB
Side Tone Masking Rating (STMR)	> 11 dB
Ringer Output	75 dB MAX
Ringer Equivalence	0.5
Set Impedance	600 Ohms Nominal
Maximum Loop	~ 4,600m (15Kft) of 22 AWG Copper

ELECTRICAL REQUIREMENTS

Ringer Sensitivity	40 -100 V, 16 - 25 Hz
Line Voltage	24 - 56 VDC
Loop Current	20 - 120 mA
Connection Method	Surge Arrestor / Terminal Block

MECHANICAL SPECIFICATIONS

Hook Switch (Cradle Switch) Life	>1 000 000 operations
Body Construction	16 Ga Mild Steel
Finish	Corrosion Protected & Powder Coated
Body Dimensions (H x W x D)	229 x 127 x 130mm (9" x 5" x 5.1")
Net Weight	1.81 kg (4 lbs)
Hand Set Construction	High impact ABS
Mounting	Vertical wall
Microphone	Noise Reducing Electret
Receiver	Hearing Aid Compatible
Hardware Material	Stainless Steel

ENVIRONMENTAL

Temperature	-40° to +60°C (-40° to +140°F)
Humidity	0 - 100% RH
Corrosion Resistant	Fully Gasketed Faceplate

COMPLIANCE

Australian Communications Authority	N14510
-------------------------------------	--------

ORDERING INFORMATION

Warranty: One year parts and labor

Order Number	Description
P6056	SCR-11-A Steel Compact Ringdown Curly Cord
P6058	SCR-41-A Steel Compact Ringdown Armored Cord

Options	Description
P004151	6 Meter (20') Curly Cord on SCR-11-A only
NC	Dynamic Noise Canceling Microphone

Guardian pursues a policy of continuous improvement, therefore specifications are subject to change without notice.



Enhancing Communications
Through Innovation and
Expertise

Qmax Group Pty Ltd.
Canning Vale, Western Australia
Ph (08) 9455-4671 Fax (08) 6210-1749
Email: info@qmax.net.au Internet: www.qmax.net.au